

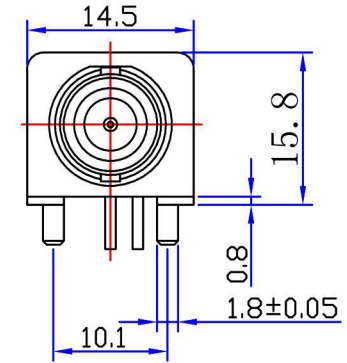

Product NO.		9001-7057		
REV	DESCRIPTION	DWN	DATE	APPROVEN
A	First issue		2012/11/02	

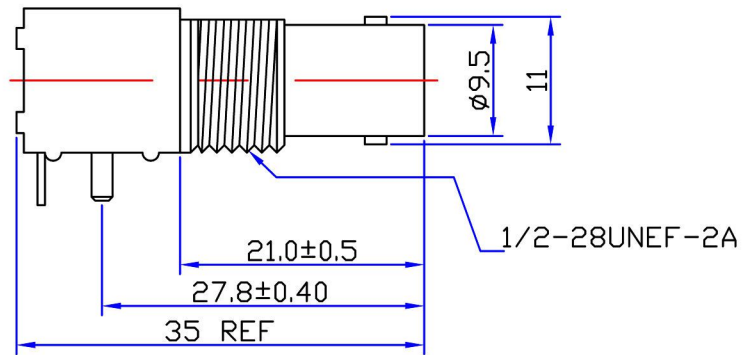
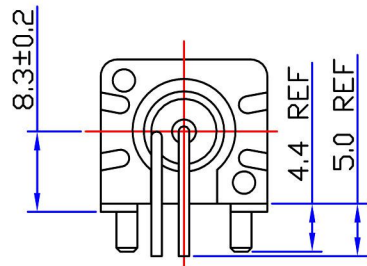

Specifications

Impedance: 50 Ohms
 Frequency Range: DC~3G
 VSWR: 1.3MAX
 Working Voltage: 500V rms @ sea level
 Insulation Resistance: 5000 Ohms min
 Temperature Range: -55°C TO +155°C
 Relative Temperature: ≤95% (40° C ± 2° C)
 Drawings products are in line with ROHS standards

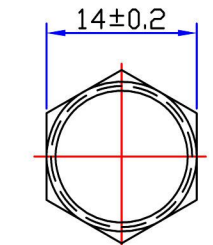
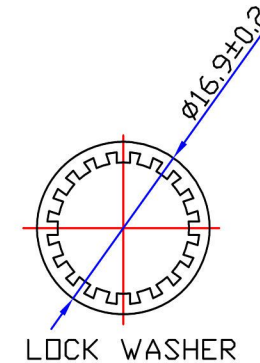
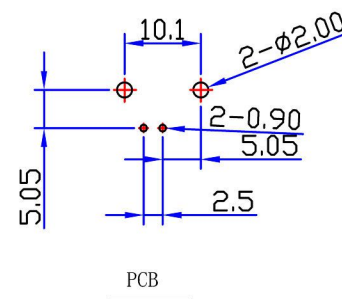
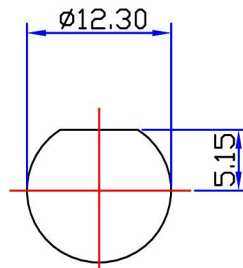

1/2-28UNEF-2B CLAMP NUT

1	Body	Zinc	NI:80-120u"	NOTE:	Tolerance	0-6	±0.15	<h1>HO CHIEN</h1> www.hochien.com					
2	Center contact	Brass	AU:1u"			6-30	±0.20						
3	Lead	Iron	AU:1u"			30-120	±0.5						
4	Fixed footrest	Iron	NI:80-120u"			Angular	±2°						
5	Insulator	POM	White	DRAWN	2012/11/10	View		Name: BNC White plastic connector (15.8mm)					
6	Fixed mount	PBT	White	CHECKED		UNIT	MM	SIZE A					
7	Washer	Brass	NI:80-120u"	APPROVALS	12/04.2012	SCALE	1:1	Product NO.	9001-7057	REV	B		
8	Hex nut	Brass	NI:80-120u"					DateTime	2012/11/02	CAD FILE	D/company drawings/BD	SHEET: 1 OF 1	
9													
10	Component Number	Material	Finish										