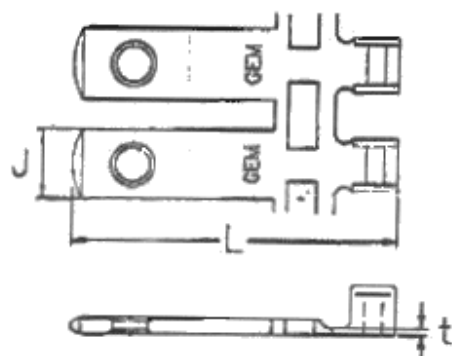
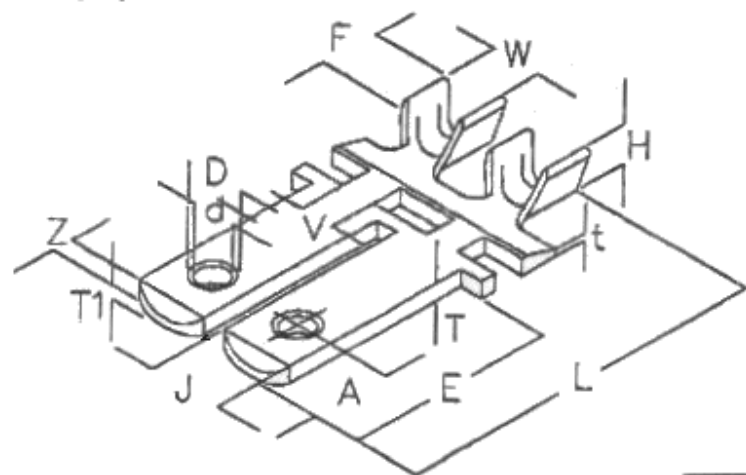

FIG : 插頭片



T: 1.5

Wire Size	Crimping Height	Crimping Width
0.75mm ²	1.97±0.05	3.00±0.05
1.25mm ²	2.12±0.05	3.00±0.05

WIRE GAUGE AWG	DIMENSIONS T x W x P	STD PKG Q'TY	NW KGS	MATERIAL /FINISH	SURFACE PROCESS	SERIAL OR SINGLE TYPE
16-18	1.46X29.7X8.25	4000	6.88kg	Brass 1/2H	-0 -1	Serial

ITEM	SPECIFICATION	REMARK	ITEM	SPECIFICATION	REMARK
T	1.5 $\begin{matrix} -0.0 \\ -0.04 \end{matrix}$		H	3.8 ± 0.30	
T1	0.6 ± 0.2		F	4.3 ± 0.30	
t	0.65 ± 0.05				
D	3.95 ± 0.1				
d	3.15 ± 0.07				
A	5.5 ± 0.15				
E	18.1 ± 0.30				
L	29.1 ± 0.30				
J	6.3 ± 0.07				
V	3.0 ± 0.20				
W	4.0 ± 0.30				
Z	1.2 ± 0.30				

DIMENSION MEASURING SCALE UNIT : mm				PART NO : 97675	
APPROVAL	<i>Ray</i>	AUDITOR	<i>[Signature]</i>	DRAWNER	<i>[Signature]</i>
				DATE : 2005 03/07	
				SCALE : 2/1	

